

Apex[®]

APEX DECKING INSTALLATION GUIDE

VERSION 3.0 | 11/10/2022



Before installing, please ensure you have downloaded the latest version of this installation guide by scanning this code.

www.eva-last.com

A PRODUCT BY **EVA-LAST[®]**
INSPIRED BY NATURE, DESIGNED FOR LIFE.

Contents

Introduction	3
1. Critical installation points	3
2. Pre-installation	5
3. Cutting and fastening	7
4. Planning and installation	12
5. Disclaimer and copyright	18
Appendix A - Profiles and compatible fasteners	19
Appendix B - Installation	21
Appendix C - Summary matrix of expansion gaps for different conditions	26
Appendix D - Corrosion references	28
Appendix E - Troubleshooting	31

Introduction

Thank you for choosing an Eva-last decking product. This guide aims to provide the essential information needed to successfully install an Apex deck. It is assumed, however, that the user of this document has a basic understanding of deck building practices and pertinent building codes. Compliance with the requirements captured herein must be met for full warranty coverage.

Apex products are made from a foamed mineral-polymer composite core, with an innovative double layer polymer cap providing a unique finish as well as improved slip resistance. See the list of profiles and corresponding fasteners captured in **Appendix A**.

1. Critical installation points

Below is a summary of pertinent points for the installation of a deck using Apex. For further detail, please refer to the relevant section of this document

Substructure:

- Plan your substructure to align with the intended deck layout.
- Ensure your substructure is level and secure.
- Use appropriate spans. The maximum centre-to-centre span for Apex is 300 mm. This span is suitable for residential applications and most other applications. Consult an appropriately qualified professional for spans above this maximum or load cases greater than 4 kPa.
- Support boards along all cut edges.
- Use double joists at all butts joins so that both board edges are fully supported.
- Use noggins between joists where breaker boards are used. The spans between noggins must not be greater than the maximum centre-to-centre span of Apex .
- Do not overhang boards by less than 10 mm and more than 20 mm from a support edge.

Fastening:

- Hulk halo (s-series) or Chain Collated Clips must be used when installing Apex profiles. The manufacturer cannot guarantee a successful install using other decking clip brands which could then affect your warranty. Please check with your regional sales representative on the best clip to use for your profile and application.
- Use two fasteners (hidden clips or top fixings) at every joist.
- Maintain a fastening (hidden clips or top fixings) edge distance of 30 mm from any board edge.
- When top fixing boards, ensure a spacing of 30 mm between fasteners.
- Do not over-tighten any fasteners. The torque setting of your driver must be less than 30 % of the maximum allowable.

Ripping:

- Do not rip groove boards narrower than 60 mm or square edged boards narrower than 90 mm.

Trim or Fascia:

- Always install your trim or fascia beneath the lip of the boarder board.

Expansion:

- Apex can expand and contract at a rate up to approximately 50% more than typical wood-plastic composite materials.
- To allow for an appropriate expansion gap (ΔL) per board, multiply the length of the board (L) by a coefficient of 0.07 (α) and by the maximum difference in temperature between the installation temperature and the possible temperature of the boards (ΔT): $\Delta L = L \times \alpha \times \Delta T$

- Please refer to **Section 3.5** in this guide for more information on this topic.
- Use the same method to estimate maximum gap size (when boards are fully contracted) to ensure this is suitable for the project
- Where the expected temperature range is high consider using lighter coloured deck boards to reduce the required expansion gap.
- To further reduce the expansion gap, boards can be cut to shorter lengths.
- Use breaker boards between boards that are installed end-to-end, and/or boarder boards around the perimeter of an installation, to assist in controlling expansion and contraction.

2. Pre-installation

2.1 Standards

Legislation may differ between jurisdictions. Before installing any Eva-last product, ensure that the application is rational and complies with the local regulations and building codes. Wherever necessary, consult a suitably qualified professional. Be sure to comply with material manufacturer specifications. Where manufacturer's specifications and building codes differ, revert to the building code requirements. Check that your choice of product is suitable for its intended application. For further product specification and information visit www.eva-last.com.

2.2 Safety

Refer to the applicable **Material Safety Data Sheet (MSDS)** for additional information. Please do not hesitate to contact Eva-last should you require any additional assistance.

Always wear appropriate Personal Protective Equipment (PPE) for the various activities involved in installing a decking system. This includes, but is not limited to, equipment such as safety glasses, helmets (where necessary), gloves and boots, dust masks when cutting or similar, and harness systems when working at heights or similar, as dictated by the local occupational health and safety legislation.

Be mindful of the following:

- Ensure to comply with the local occupational health and safety legislation.
- Cutting (and similar processing activities) Apex produces fine particulate matter, as a result, ensure to:
 - Work in well-ventilated areas.
 - Use tools with vacuum attachments.
 - Wear dust masks during cutting, drilling, and cleaning.
 - Wear safety goggles whilst cutting and installing.
- Cut boards may have sharp edges (particularly mitered cuts).
- Clean workspace thoroughly. Wet-wipe, mop, or vacuum surfaces. Do not dry sweep as this can disperse the dust. Use of drop sheets may assist.
- Wear appropriate PPE when working with boards.

2.3 Storage and handling

Note the following:

- Individual boards are lighter than typical wood-plastic composites (WPC) and can be more easily handled. Boards are, however, bundled for convenience which can be heavy. Take care when lifting, placing on to, or removing from raised pallets. More than one person may be required for lifting depending on the length of the boards and the number of boards. Ensure the mass handled does not exceed safe limits as defined by applicable local legislation.
- When handling lengths of boards greater than 4 m, ensure both ends are lifted simultaneously and evenly. Hold the boards 1 m from each end to provide better control.
- Handle the boards carefully. Dropping the boards (and all high impact loads in general) can result in damage to the profiles.
- During transportation use corner protectors where strapping is required.
- All components should be stored completely under cover.
- When storing boards, a pallet or flat surface should be used to support the full length of each component.
- All components should be securely stored.
- No component should sit in water or similar.
- Avoid over-stacking and/or eccentric stacking.

2.4 Planning and site preparation

- Consult an appropriately qualified professional whenever necessary to ensure the product, this document and the intended application complies with all applicable legislation for that region.
- Assess the environment of the site and ensure the product is suitable for the intended application.
- Identify aspects such as the corrosion category, loading class, etc. of the site and project that may influence the selection of the products or the application thereof.
- Determine appropriate spans for the selected material technology and profile. This will depend on the application as well as the loading class as defined by the local legislation. Suggested spans are provided for typical residential scenarios (refer to **Section 4**).
- Decking at certain heights will require railing. Refer to the local legislation, or consult a suitably qualified professional, for guidance as to at what height this is required at and the railing requirements thereof.
- Develop a maintenance plan to ensure the longevity of the system. This should consider aspects such as drainage, corrosion, vegetation growth, cleaning, etc.
 - With respect to drainage, ensure pooling water and/or erosion below and around the deck footprint is prevented.
 - With respect to corrosion, ensure any exposed metals are coated whilst accessible. In areas of high corrosion classes, add additional coating layers and regularly check for signs of corrosion.
 - With respect to vegetation below the deck footprint, ensure all vegetation has been removed prior to installing the deck. Install a suitable geotextile or plastic membrane to prevent further regrowth. Ensure the geotextile/membrane is fixed in place and protected from weathering.

3. Cutting and fastening

3.1 Cross cutting

- Please ensure that the appropriate PPE and safety precautions are adhered to whilst cutting Apex material.
- Use a fine toothed, carbide tipped blade to cut Apex material.
- Use an 80-tooth or finer, 260 mm diameter, cross-cut blade.
- Apex boards are provided as factory cut. Ends should be trimmed to carpentry cut.
- Boards can be mitred, angles less than 30° are to be avoided.
- Do not router Apex boards.

3.2 Ripping

- For best results when ripping composite boards use a table saw or ripping jig.
- Cutting boards will expose the foamed core of the board. Plan the board layout/install appropriately to limit the visibility of these edges so as not to negatively impact the aesthetics of the install.
- Do not rip boards thinner than 60 mm for grooved boards or 90 mm for square edged boards.
- In the case where it would be necessary to cut a board to less than 60 mm wide, rip both the first and last board of the deck footprint to balance the required widths instead. Refer to below infographic for guidance

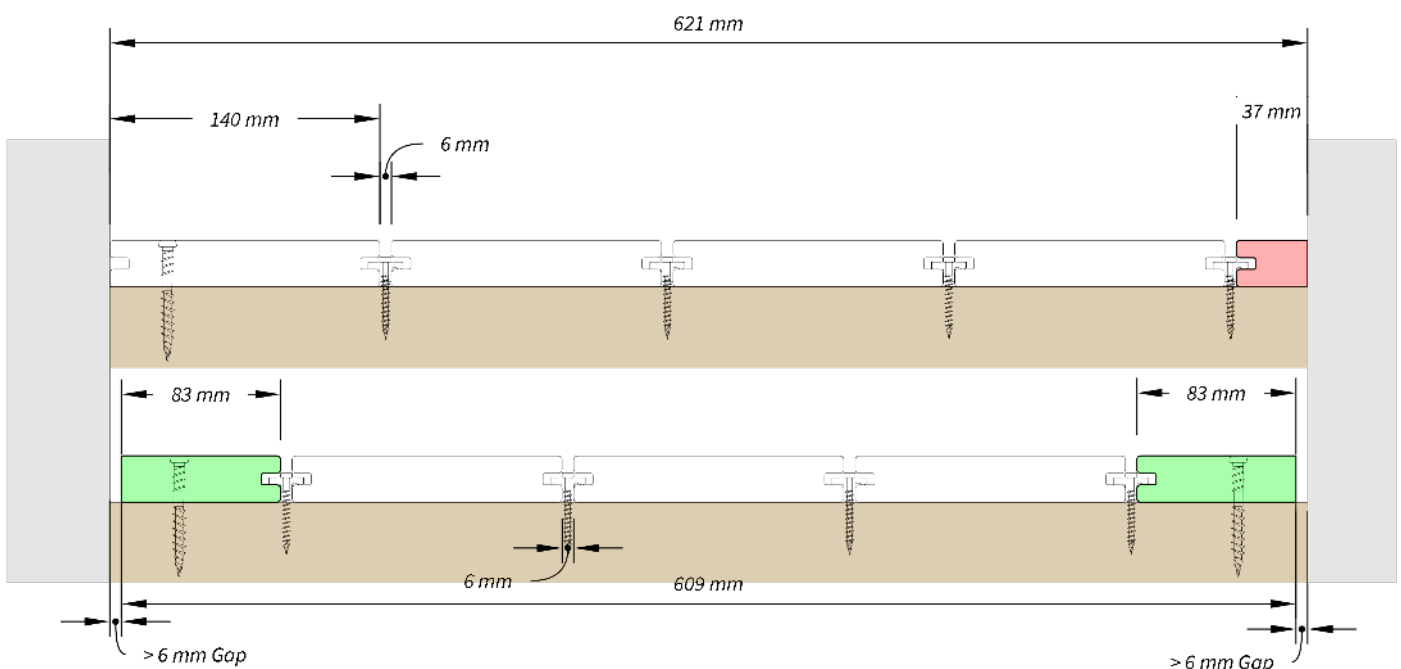

3.3 Top fixing

- When top fixing boards, fasten the boards 30 mm from any edge of the board.
- When top fixing boards, adjacent screws should be 30 mm apart.
- Fasten every joist and use a minimum of two fasteners per joist to board connection.
- Ensure a board overhang is never more than 20 mm.
- Pre-drill composite in temperatures below 5°C, pre-drilling hole sizes should be equal to the minor diameter of the screw.
- Do not use nails to fasten Apex boards.

- Use high quality fasteners suitable for the life span of the deck and the atmospheric conditions of the site. Consider the corrosion category of the site relative to the corrosion protection offered by the fastener. Consult with a suitably qualified professional where necessary. Feel free to also contact a member of Eva-last for further assistance.
- A drill with adjustable torque settings is recommended. Set the torque settings to less than 30 % of the maximum allowable torque of the driver. Do not over drive the screw. Do not use an impact driver.

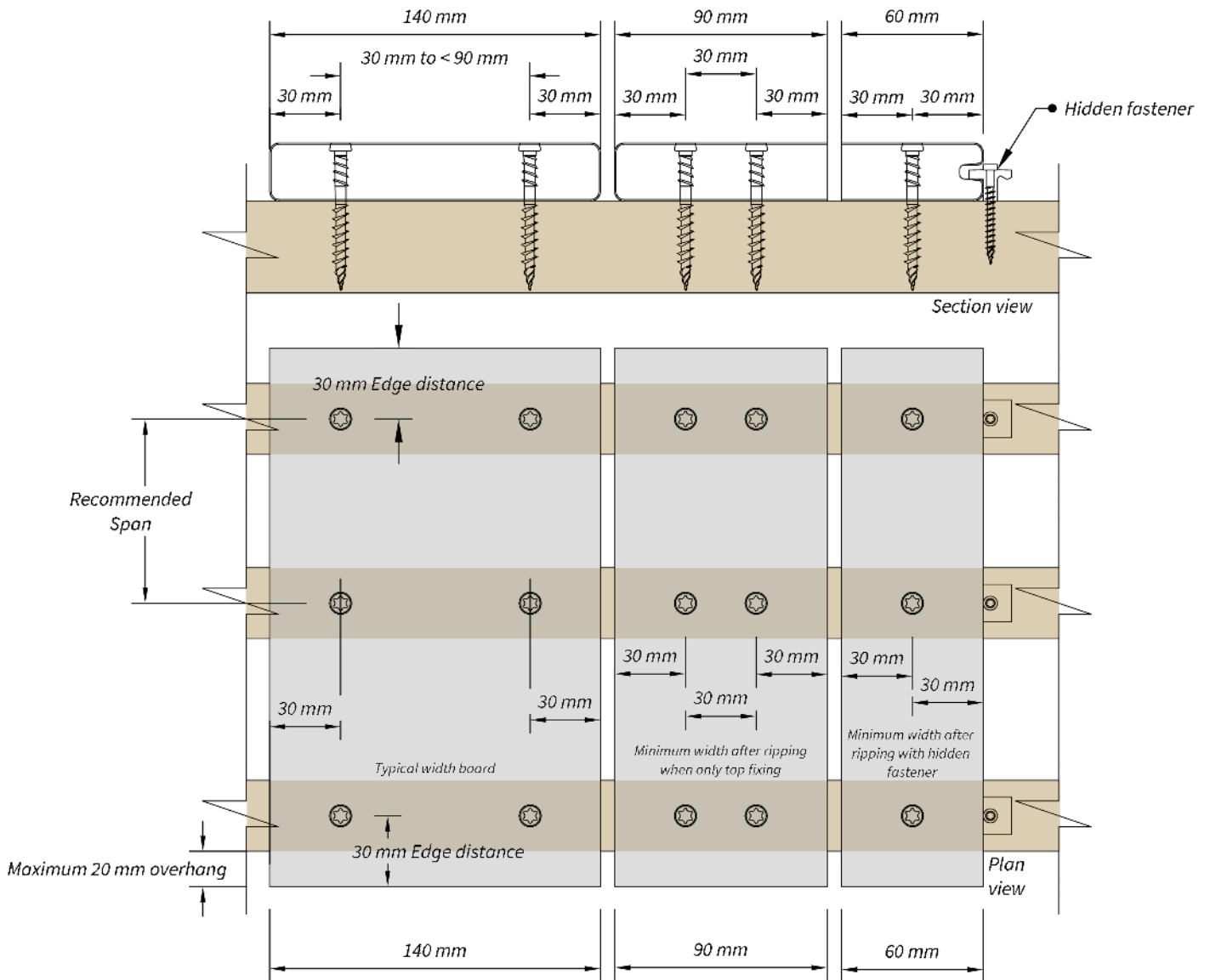

3.4 Cutting and fastening triangular pieces

- Where deck boards are cut to odd shapes, additional fasteners may be required.
- All three edges of a triangular piece should be supported. All three corners of a triangular piece should be fastened.
- Spacing between fasteners and to any edge must be 30 mm.
- Geometry of triangular pieces are limited by the fastening and edge distance. Below diagrams provide an indication of minimum allowable sizes of different theoretical triangular pieces.

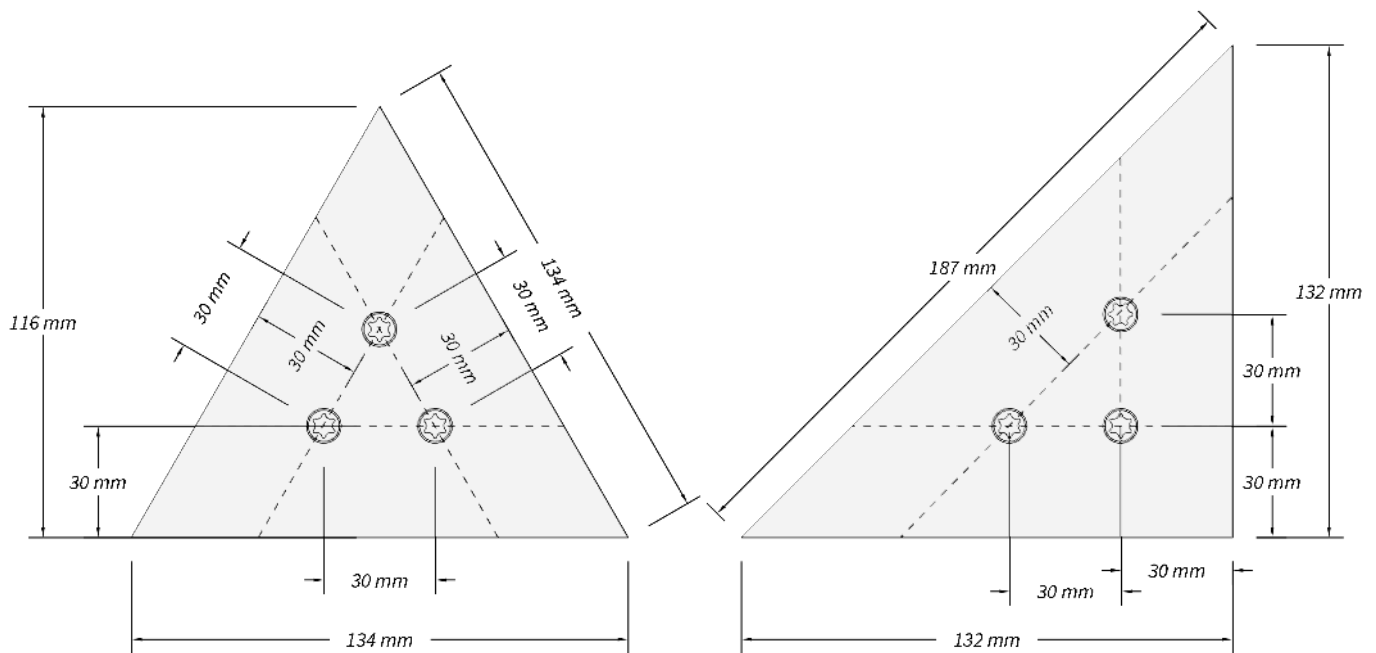

3.5. Cutting length

Before boards are laid, the final cut length of a board must take into consideration the possible changes in length of the board due to thermal expansion and contraction. Appropriate expansion gaps must always be maintained between boards and/or between boards and other obstacles for full warranty coverage.

3.5.1 Fundamentals of expansion and contraction

- The expansion, and contraction, of a board is influenced by:
 - The material of the board,
 - The length of the board, and
 - The change in temperature the board experiences relative to the temperature of the board at installation.
- The linear coefficient of expansion for the Apex material technology is up to $70 \times 10^{-6} \text{ mm/m/}^\circ\text{C}$. This means that a board of this material can expand, and contract, up to 0.07 millimetres per meter length, per degree change in temperature. This is an expansion and contraction rate that is approximately 50% more than Infinity or Eva-Tech.
- To estimate an appropriate expansion gap (ΔL) per board, multiply the length of the board (L) by a coefficient of 0.07 (α) and by the maximum difference in temperature between the installation temperature and the possible temperature of the boards (ΔT): $\Delta L = L \times \alpha \times \Delta T$
- The temperature change of the board will be influenced by the colour of the board. Darker board colours will result in board temperatures higher than the ambient temperature of the site.
- A summary matrix of expansion gaps for different temperature and length conditions is captured in **Appendix C** for convenience.

3.5.2 Installation best practice for boards that expand and contract

- Allow boards to acclimatise on site before installation so that the movement of the boards across the installation is more uniform.
- Uniform board movement, similar board lengths, and consistent installation temperatures can make planning for expansion gaps easier.
- Care must be taken in environments susceptible to generating large changes in board temperature. In addition to sites with extreme ranges of temperature, this can include areas with large reflective surfaces, such as metal and glass, from rooves, facades, windows, doors, etc.
- For sites with extreme temperature ranges, lighter board colours are advised to help mitigate against large board movements.
- Use breaker boards between boards that are installed end-to-end, and/or boarder boards around the perimeter of an installation, to assist in controlling expansion and contraction.

- Use shorter board lengths to reduce the size of expansion and contraction gaps.
- For sites with extreme temperature ranges, longitudinal boards can be cut in half and multiple breaker boards installed at butt joints.
- A gap between parallel boards must be maintained at between 5.8 mm and 6.5 mm, irrespective of the type of fixing used. The same sized gap should be utilised between boards and any other obstruction. These spaces will allow for expansion and contraction as well as assist with drainage, ventilation, and the removal of debris.
- When using hidden fasteners at sites with extreme temperature ranges, additional top fixers can be installed at the joist closest to the mid-point of the board. This pins the board at the centre, allowing equal expansion in both directions of the board.
- Fixing (both hidden and visible) at every joist can be utilised to further limit expansion and contraction. In these scenarios, it is important to fix the board twice at every joist.
- When aesthetically suitable, skirting boards, cladding, facades, and similar can be installed at intersections between walls and deck boards to help hide gaps.
- Unobstructed clearance between the ground and a deck can assist with ventilation which can help moderate temperature fluctuations.
- Check maximum expected contraction of a board to ensure large gaps do not develop at low temperatures.

3.5.3 Determining expansion and contraction gaps

Below is a set of steps to assist with estimating the size of the required expansion gaps for an installation. It is necessary to install deck boards with appropriate expansion gaps to avoid negative impacts on adjacent boards.

These steps can be replicated to estimate the potential maximum contraction of a board. This is done using an estimated 'minimum board temperature' in place of the estimated 'maximum board temperature' in Steps 1 and 4. Estimating the contraction is useful in establishing what the maximum gap between boards may be at low temperatures, and whether this will be acceptable to the client. In addition, gaps greater than 20 mm can result in exposure of fasteners and underlying substructure.

1. Estimate the historical maximum (or minimum) site temperatures. Use this to estimate anticipated board temperatures, making allowances for increased surface temperatures due to board colour and/or additional exposure to temperature/sunlight. Darker coloured boards can get up to 15°C hotter than the ambient temperature. Site conditions such as reflective surfaces can further increase this estimate. For sites with anticipated high temperature ranges, it is advisable to use lighter coloured boards. [**Maximum (or minimum) board temperatures**]
2. Estimate, or measure, current install temperature of the boards, making the same allowances as above where applicable. This may have to be repeated for large sites where the installation time can extend over several hours or days. [**Install board temperature**]
3. Based off the planned deck layout, determine the required board length. This will naturally have to be repeated for layouts where multiple board lengths are required. [**Board length**]
4. To estimate the **Change in board length (ΔL)**, multiply the **Board length (L)** by a coefficient of 0.04 (**α**) and by the difference in temperature between the **Install board temperature** and the **Maximum (or minimum) board temperatures (ΔT)**: $\Delta L = L \times \alpha \times \Delta T$

Where ΔT = **Maximum board temperature** minus **Install board temperature** or ΔT = **Install board temperature** minus **Minimum board temperature**

This is the possible increase in board length if the board were to experience the estimated maximum board temperature. It is also equivalent to the **expansion gap** required at the time of installation. This is shared at both ends of the board.

Or this is the expected **maximum contraction gap** if the board were to experience the estimated minimum board temperature. This is shared at both ends of the board.

5. Determine the length to which the supplied boards should be cut to satisfy the required board length and the required expansion gap. [**Final board length**]

Below is an example of implementing the above steps for a deck in Bloemfontein, South Africa. The intended colour of the boards will be one of the darker colours. The deck layout results in a typical board length of 5 300 mm with no boards installed end-to-end (i.e. breaker boards are utilised). Note that if boards were to be installed end-to-end the expansion/contraction gaps between consecutive boards would double.

Step	Parameter	Pioneer	Unit	Note
1	Linear coefficient of expansion	0.00004	mm/m/°C	
	Maximum historical site temperature	40.00	°C	Data from online search.
	Estimated maximum board temperature	55.00	°C	15°C added for a darker board.
	Minimum historical site temperature	-10.00	°C	Data from online search.
	Estimated minimum board temperature	-10.00	°C	
2	Install board temperature	32.00	°C	Measured from the board on site.
3	Board length	5300.00	mm	Based on site layout.
4	Positive change in board length ($L \times \alpha \times \Delta T$)	4.9	mm	Maximum board temperature less install temperature.
	Total expansion gap required	4.9	mm	
	Expansion gap required at either board end	2.4	mm	Half total expansion gap required. Rounded up.
5	Negative change in board length ($L \times \alpha \times \Delta T$)	8.9	mm	Install temperature less minimum board temperature. Rounded down.
	Potential total maximum contraction gap	13.8	mm	Expansion gap plus negative change in board length. Rounded down.
	Potential contraction gap at either end	6.9	mm	Half total potential contraction gap. Rounded down.
6	Final board length	5295.1	mm	Board length minus total expansion gap required.

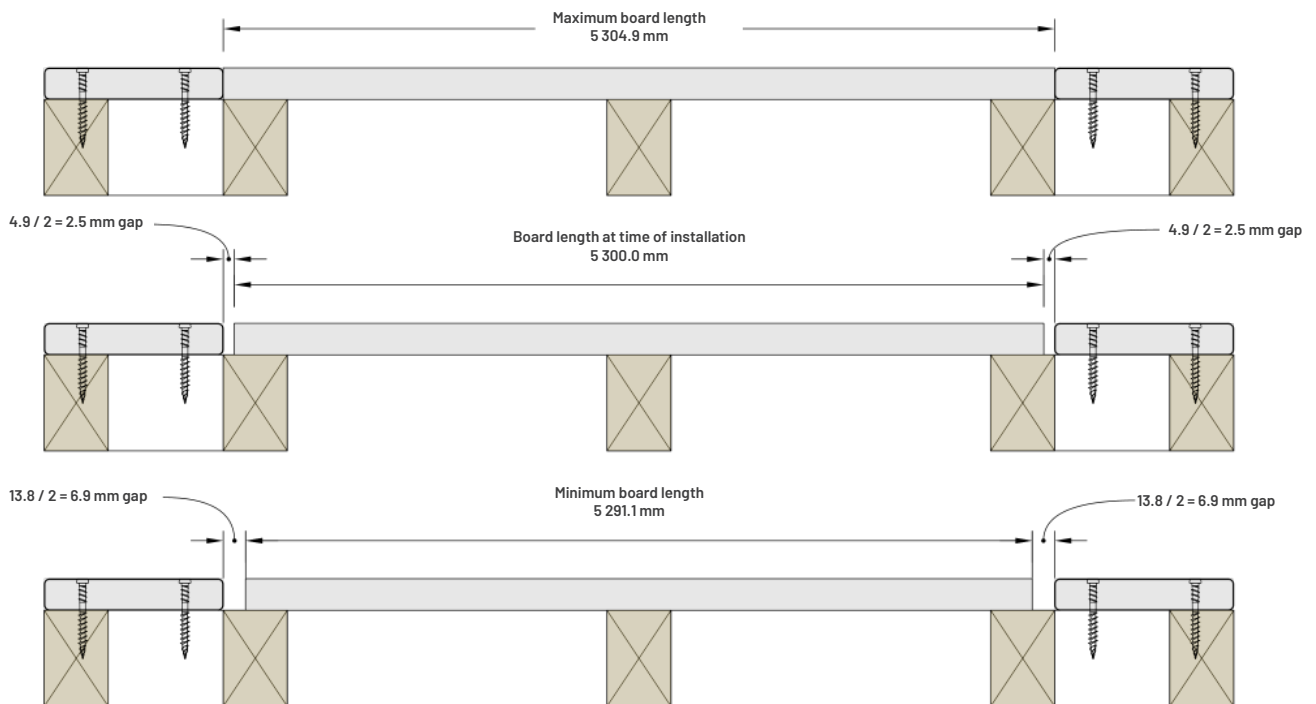

4. Planning and installation

4.1 Substructure planning and installation

Below are guidelines to consider during the planning and installation of deck substructure:

- Ensure the substructure members are appropriately sized. Ensure the installation thereof is sound and level. Consult an appropriately qualified professional wherever necessary.
- Use appropriate spans. The maximum centre-to-centre span for Apex is 300 mm or 12". This span is suitable for residential applications and most other applications. Consult an appropriately qualified professional for spans above this maximum or load cases greater than that of a typical residential application.
- Where boards are not installed perpendicularly to joists, the joist spacing must be modified to ensure that the board spans do not exceed the specified span for Apex. See below table and figure for explanation thereof:

Typical spans		Resultant span (mm) at different board angles			
		30°		45°	
		mm	Inches (")	mm	Inches (")
300 mm	12"	260 mm	10.24"	212 mm	8.35"

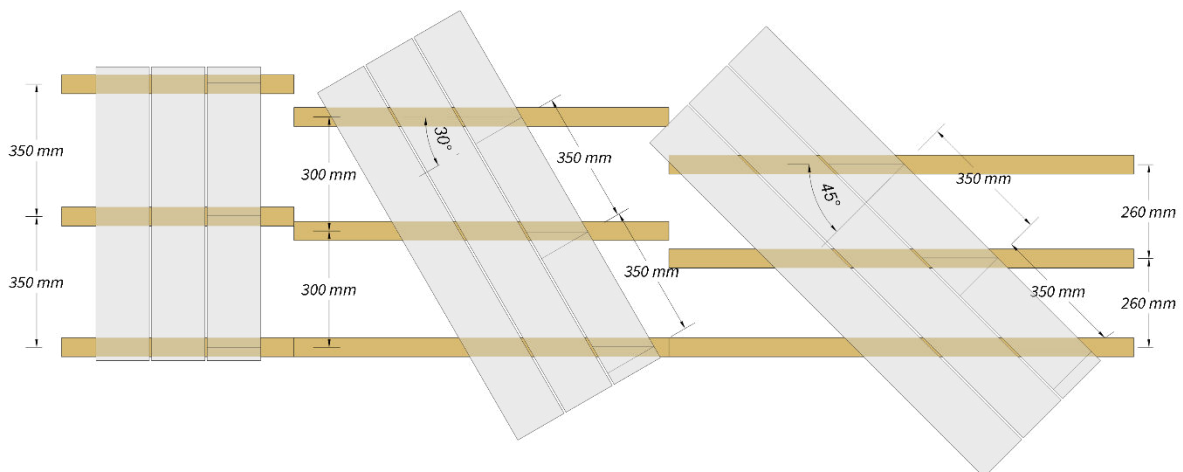

- Support boards along all cut edges.
- Use double joists at all butt joints so that both board edges are fully supported.
- Use noggins between joists where breaker boards are used. The spans between noggins must not be greater than the maximum centre-to-centre span of Apex .
- Do not overhang boards by more than 20 mm from a support edge.
- Allow for clearance between the ground and deck, and between the deck and other potential obstructions, such as doors opening out over the deck.
- Allow for drainage and water control. Consult a suitably qualified professional if required.
- Allow for railing where necessary. Consult a suitably qualified professional if required.

4.2 Decking planning and installation

Below are guidelines to consider during the planning and installation of decking:

- The layout of a deck is often dictated by existing geometrical constraints on site. Best practice involves optimisation between the standard dimensions and constraints of the deck boards supplied with the desired aesthetics of the layout.
- Attempt to keep layouts symmetrical. As a result, where it is necessary to rip boards, rip both the first and last board of the deck footprint equally to balance the required widths. Where possible, avoid ripping boards at all.
- An ideal expansion gap size at maximum contraction would be 6 mm to match that of the typical gap between boards installed parallel to each other.
- Use breaker boards and boarder boards to provide an aesthetically pleasing finish whilst assisting in controlling expansion and contraction.
- Use multiple combinations of shorter boards with breaker boards to balance long runs against expansion and contraction limitations.
- Butt joints can be installed so they align or are staggered. Both options have advantages and limitations with respect to aesthetics and installation practicality.
- Consider the orientation of the boards relative to typical foot traffic direction as well as the site layout. Typical approaches are to install deck boards parallel with the longest dimension of the site layout. In areas where better slip resistance is required, most composite textures have better slip resistance with the boards orientated perpendicular to common foot traffic direction. In general, Apex deck boards have good slip resistance characteristics in all board orientations (please refer to the Apex **TDS** for further information). Additionally, consider the length of the available space in relation to the lengths and widths of the boards available. In some cases, certain orientations can be very efficient from a material perspective. Finally, consider existing obstructions and their straightness, it is easier to cut board ends than it is to rip along board lengths to match uneven surfaces such as poorly built walls, flower beds, etc.

4.3 Decking planning and installation

Below is a brief set of steps to assist with optimising a layout so that the site and environmental influences, client requirements, and material impacts are taken into consideration.

1. **Layout and environment:** Determine site layout/footprint and establish any critical environmental parameters that may influence the installation or performance of the installation. Particular aspects to consider include extreme temperature ranges, high corrosion classes, large catchment areas, steep slopes, etc.
2. **Optimisation:** Optimise deck layout relative to the site layout and the deck board dimensions. Incorporate allowances for the established critical environmental aspects in Step 1. Cater for additional factors that may influence the layout such as expansion and contraction, preferred aesthetics, foot traffic, existing obstructions, clearances, railing, etc. This step may take several iterations. Establish the primary board orientation first, then incorporate supporting elements, such as breaker boards, perimeter boards, etc. where necessary. Once finalised, the quantity of deck boards can be determined.
3. **Substructure, fasteners and ancillaries:** With a layout finalised, the substructure can be outlined based on the required supports and spans. Aspects such as supports for railing, pergolas, etc. must be allowed for at this stage. Once established, the deck board and substructure layout will allow the type and number of fasteners required to be calculated. Ancillary items such as railing, pergola etc. parts, can then be quantified.

The digram on page 13, below, is an example that lays out the implementation of the steps suggested above. The same example deck discussed in **Section 3** is incorporated.



LOCATION AND MACRO ENVIRONMENTS

Bloemfontien is located on the southern edge of the South African highveld with record temperatures ranging between **40 °C and -10 °C**, while falling under a typical **C3 Class (moderate) atmospheric corrosion category** with low salinity and only moderate pollution.



SITE ASSESSMENT OF THE MICRO ENVIRONMENT

A site assessment provided more **specific details surrounding the building site and its environment**

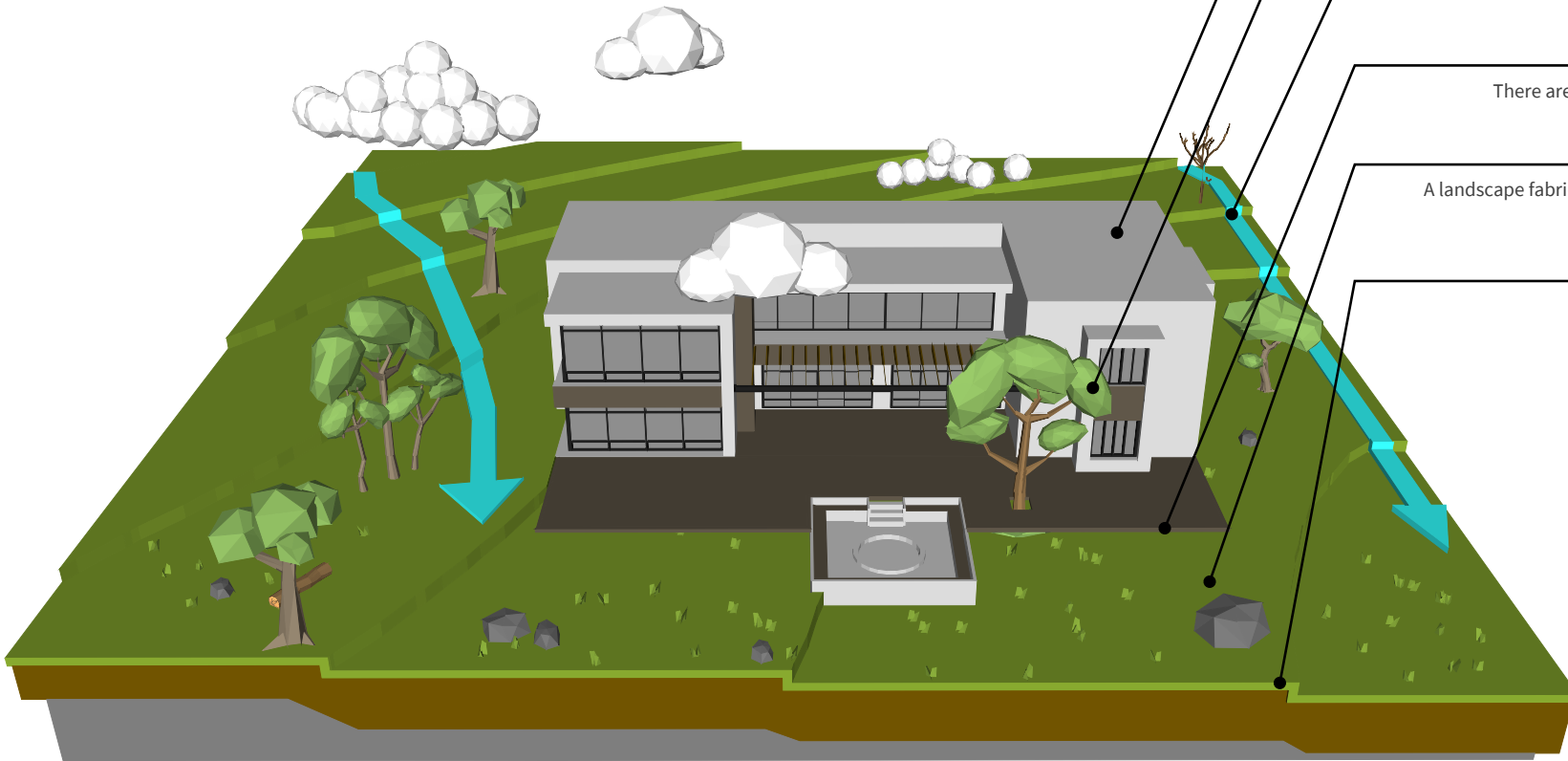

PROPERTY TYPE

Residential

EXISTING FEATURES

An existing recessed Fire pit 450 mm drop .

HYDROLOGICAL

The deck requires no further intervention as water flows away from the deck to natural water catchment areas

UTILITIES

There are no utilities running across the footprint of the deck.

VEGETATION

A landscape fabric or plastic sheet should be applied beneath the deck to prevent vegetative growth beneath the deck.

TOPOGRAPHICAL

The ground has 2° slope resulting in a 900 mm drop from the final required floor height.



CUSTOMER PREFERENCES

The client has specified **Apex™ decking** in the **Brazilian teak (dark brown) colour**, with the boards **running perpendicularly away from the building**.



Board

Apex grooved deck board

Colour

Brazilian teak (Dark brown)

DECK ASSESSMENT

A appropriately qualified professional has specified the structure and fastener combination to meet the environmental and loading requirements for the deck. In this example the professional has specified a galvanised steel frame and composite to steel deck fastener, specific to this site. The footprint of the deck has been assessed in relation to the dimensions of the specified deck board.

As boards are 5 450 m lengths, Two boards will be required to cover this length

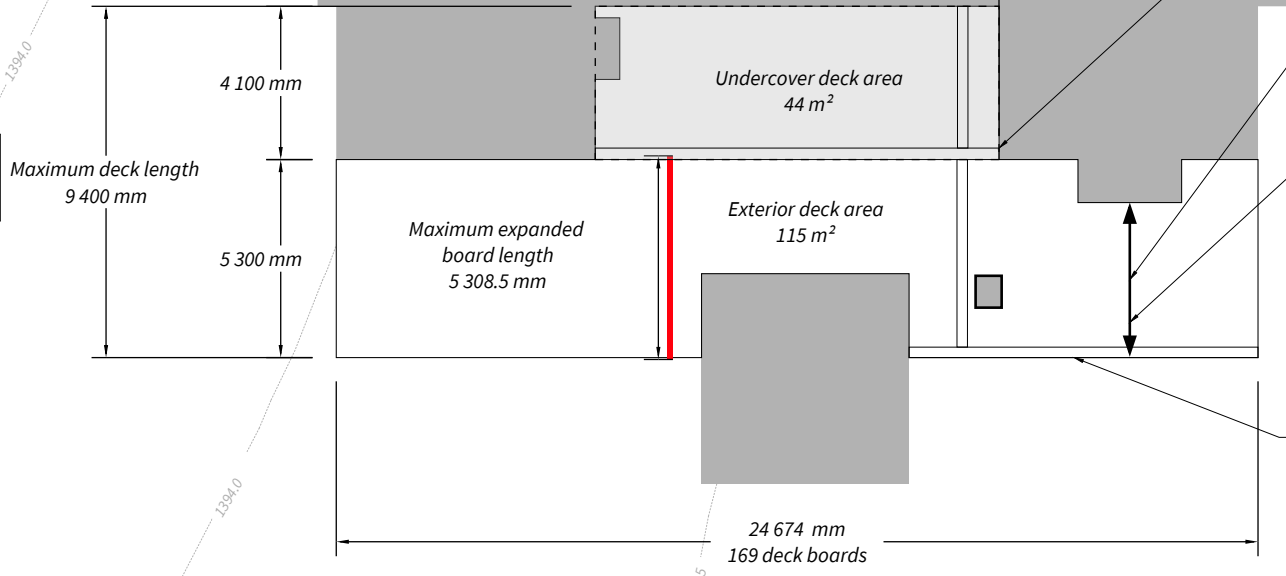

BOARD WIDTHS AND GAPS

Before laying boards, consider the cover width of a deck board (board width plus fastener gap), particularly in enclosed areas .

BREAKER BOARD AND BOARD LENGTH

The deck is 9 400 mm long while deck boards are a maximum of 5 450 mm, requiring a join at some point. A breaker board can be used to control expansion gaps.

BOARD DIRECTION

The laying direction has been specified.

SLIP RESISTANCE

Board laying direction and finish have an impact on slip resistance. See the TDS for Slip resistance information.

RIM BOARDS

Starter boards and breaker boards can be used to finish and hide the deck edge.

LIFESPAN DESIGN

The design life of a deck system requires balancing the lifespans of the individual components, to the part with the lowest life span. The system life expectancy can be extended with proactive maintenance, painting, and replacing parts once the part expires.

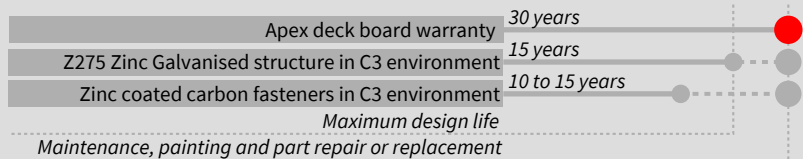

EXPANSION GAP CALCULATION

The final cut length of a board must take into consideration the possible changes in length of the board due to thermal expansion and contraction. The below infographic provides a summary of the example provided in section 3.5.2. as applied to the above deck example.

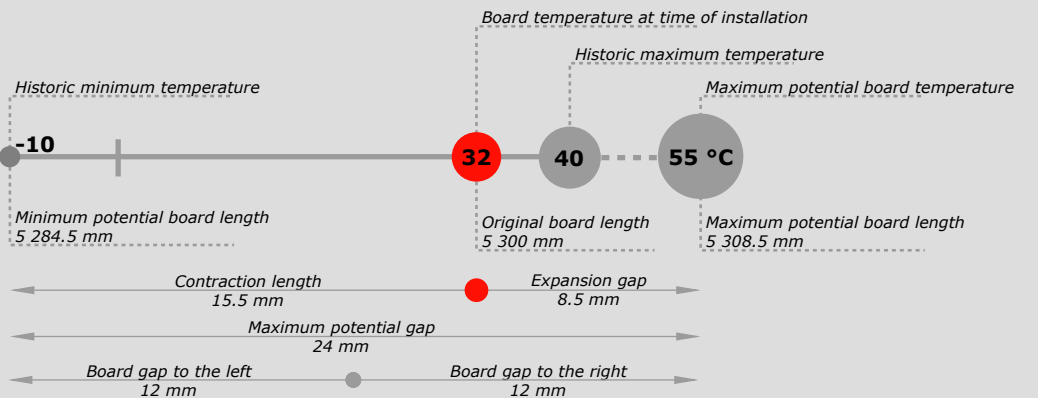

DECK STRUCTURE AND LAYING PATTERN

The deck laying pattern will impact the final design of the structure.

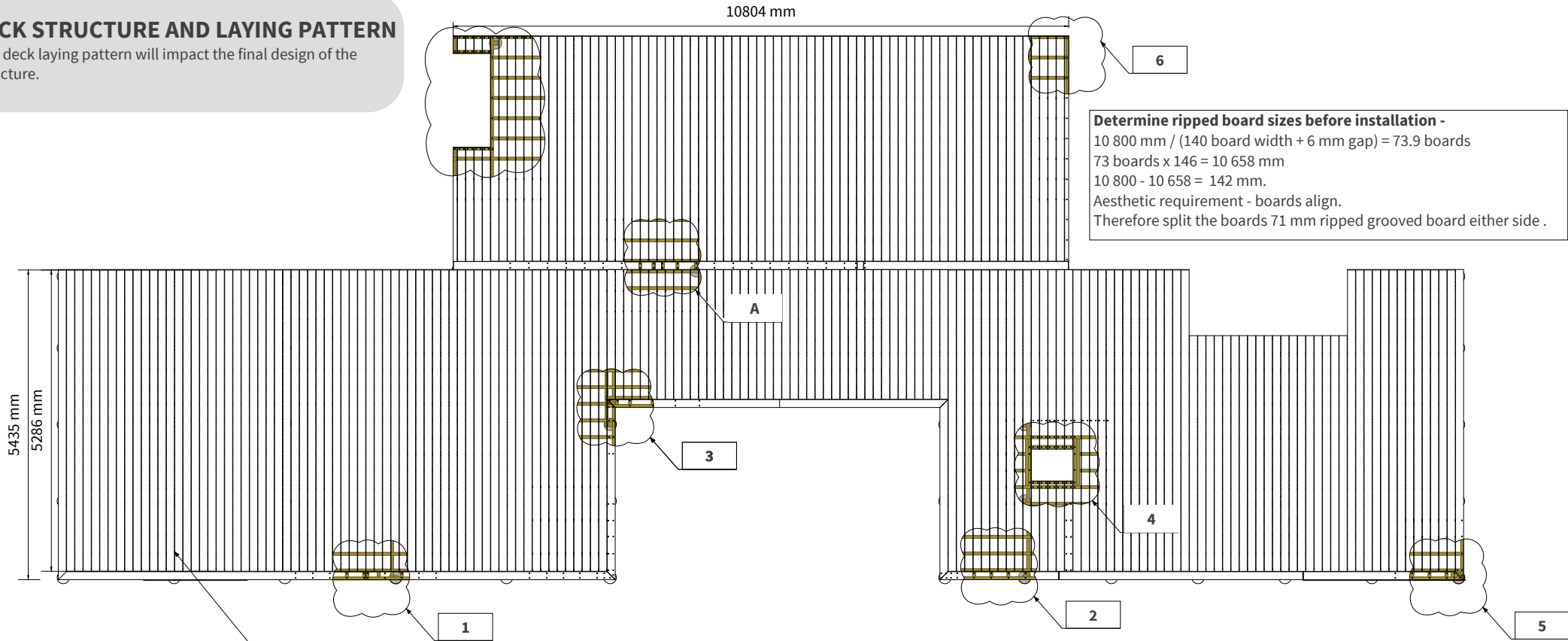

Determine ripped board sizes before installation -
 $10\ 800\ \text{mm} / (140\ \text{board width} + 6\ \text{mm gap}) = 73.9\ \text{boards}$
 $73\ \text{boards} \times 146 = 10\ 658\ \text{mm}$
 $10\ 800 - 10\ 658 = 142\ \text{mm.}$
 Aesthetic requirement - boards align.
 Therefore split the boards 71 mm ripped grooved board either side .

LAYING PATTERN PLAN

Expansion gap for 5 300 mm board per example outlined in section 3. at 8.5 mm at each end

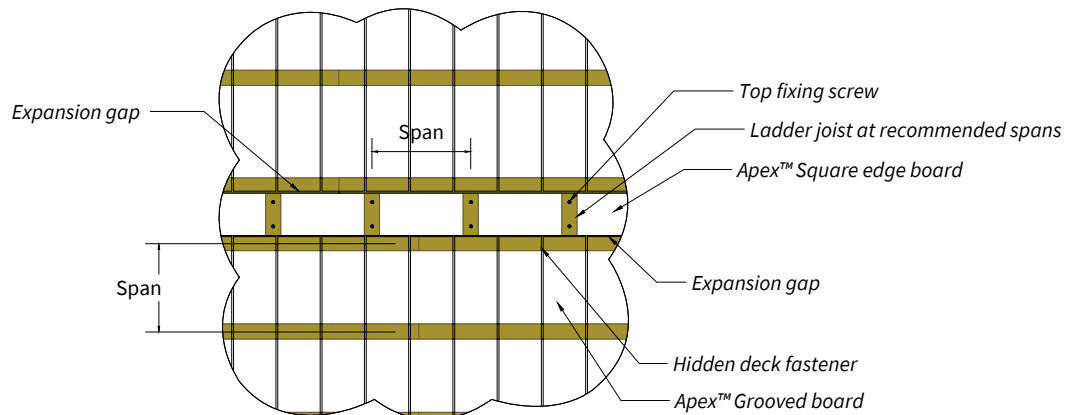

A Breaker board detail

Deck schedule			
Profile	Size	Board length	Profile
Square edge	140 x 24 mm	5 450 mm	
Grooved	140 x 24 mm	5 450 mm	

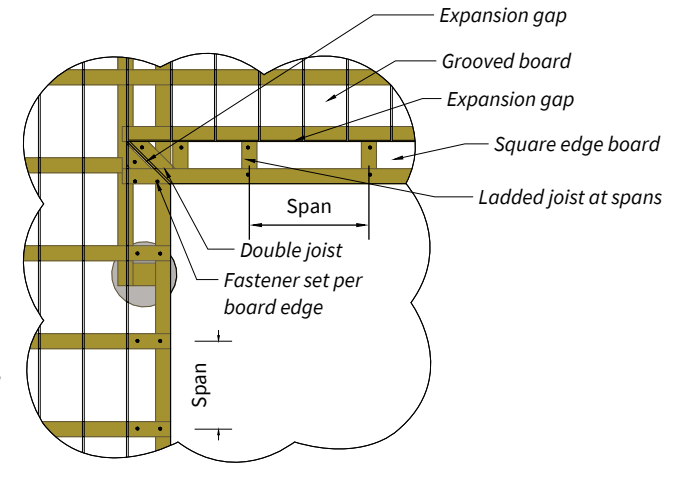
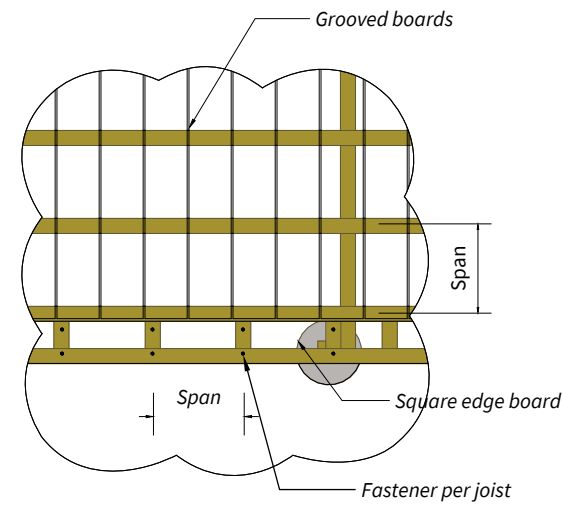
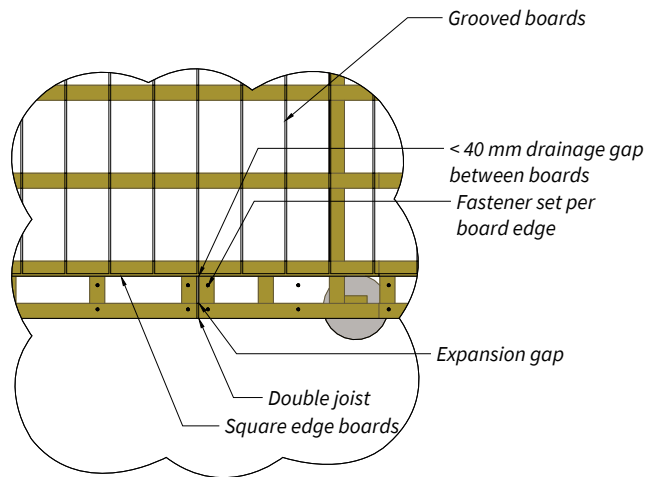

1 Double joist on abutting boards

2 Ladder joist for breaker boards

3 Mitre joint detail on breaker boards

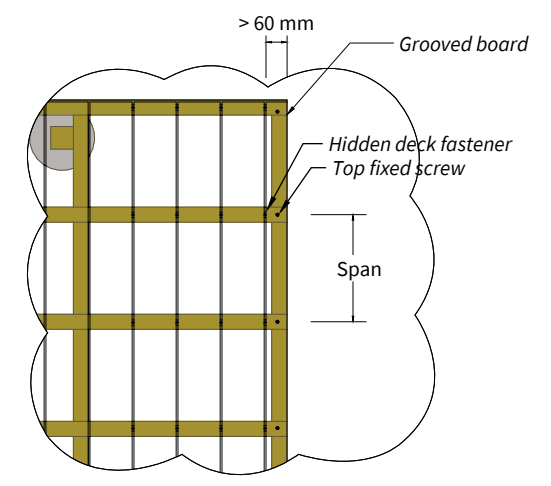
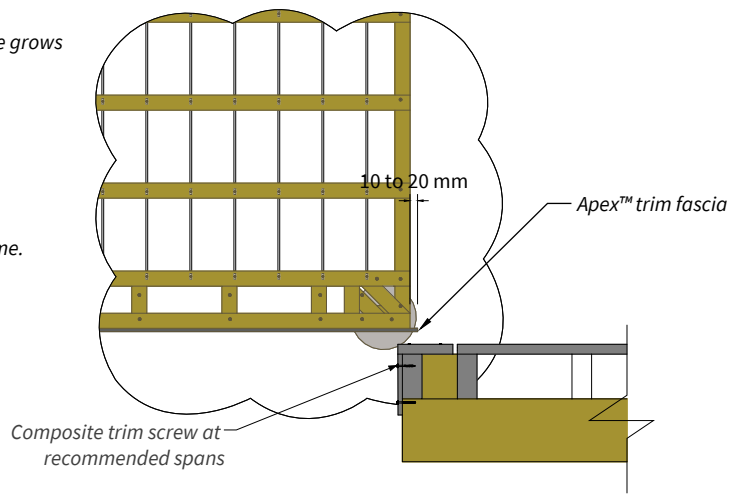
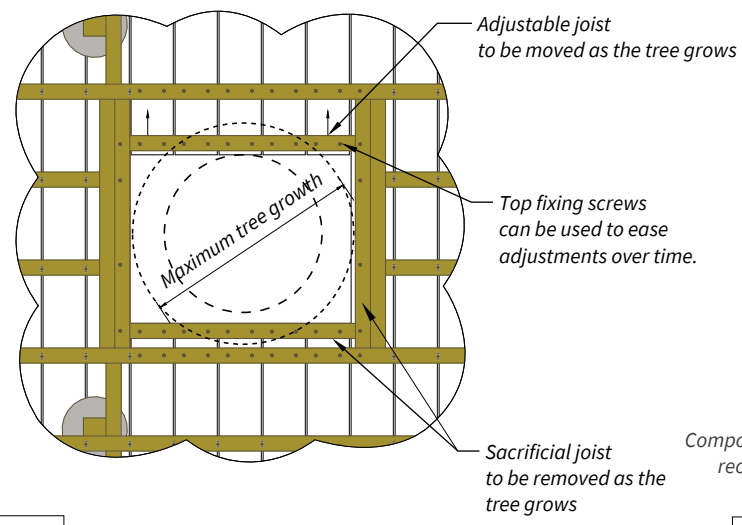

4 Board support around a tree

5 Trim detail

6 Ripped board detail

5. Disclaimer and copyright

5.1 Document disclaimer

The provided information is offered in good faith as accurate but without guarantee. Eva-Last makes no warranties or representations of any kind (express or implied) about the accuracy, adequacy, currency, or completeness of the information, or that it is necessarily suitable for the intended use.

Compliance with this document does not guarantee immunity from breach of any statutory requirements, building codes or relevant standards. The final responsibility for the correct design and specification rests with the designer and, for its satisfactory execution, with the contractor. Appropriate warnings and safe handling procedures should be provided to handlers and users.

While most data have been compiled from research, case histories, experience and testing, small changes in the environment can produce marked differences in performance. The decision to use a material, and in what manner, is made at your own risk. The use of a material and method may therefore need to be modified to its intended end use and environment.

Eva-Last, its directors, officers or employees shall not be responsible for any direct, indirect, or special loss or damage arising from, or as a consequence of, use of, or reliance upon, any information contained in this document or other documents referenced herein. Eva-Last expressly disclaims any liability which is based on or arises out of the information or any errors, omissions or misstatements herein.

5.2 Drawing disclaimer

All dimensions and specifications are offered in good faith as accurate but without guarantee. The information captured herein may not contain complete details. Eva-Last makes no warranties or representations of any kind (express or implied) about the accuracy, adequacy, currency, or completeness of the information, or that it is necessarily suitable for the intended use.

Compliance with this document does not guarantee immunity from breach of any statutory requirements, building codes or relevant standards. The final responsibility for the correct design and specification rests with the designer and, for its satisfactory execution, with the contractor.

5.3 Utilisation disclaimer

Legislation may differ between jurisdictions. Before installing any Eva-Last product, ensure that the application is rational and complies with the local regulations and building codes. Wherever necessary, consult a suitably qualified professional. Be sure to comply with material manufacturer specifications. Where manufacturers and building codes differ, revert to the building code requirements. Check that your choice of product is suitable for its intended application. For further product specification and information visit www.eva-last.com.

5.4 Copyright

If reprinted or reproduced or utilised in any form Eva-Last should be acknowledged as the source of the information.

Eva-Last periodically updates the information contained in this document as well as that of the Eva Last documents that have been referenced herein. Before using this document, please refer to the Eva-Last website (www.eva-last.com) for the most up-to-date documents.

Contact information

Eva-Last

Room 1203, 12/F Tower 333 Canton Road, Tsimshatsui, Hong Kong, China

Email: info@eva-last.com

Website: www.eva-last.com

Appendix A

Profiles and compatible fasteners

See TDS for additional information where required.

A.1 Apex profile family

Below is a summary of profiles available in the Apex material technology.

Code	Cap	Description	Width (mm)	Depth (mm)	Common lengths (mm)	Coverage* (m/m ²)	Mass per meter (kg/m)
STPVB101	Full cap	Grooved deck board	140	24	5 700	6.8	2.5
					5 450		
					4 800		
STPVB102	Full cap	Square edge board	140	24	5 700	6.8	2.5
					5 450		
					4 800		
STPVB103	Half cap	Grooved deck board	140	24	5 700	6.8	2.5
					5 450		
					4 800		
STTHM116	Half cap	Grooved deck board	190	24	5 700	5.1	3.4
					5 450		
					4 800		
STTHM106	Half cap	Fascia board	150	12	2 200	6.4	1.4
STTHM111	Half cap	Fascia board	184	14	2 200	5.3	1.9
STTHM112	Half cap	Fascia board	285	16	2 200	3.4	3.4
STPVB104	Full cap	Batten	30	40	2 800	N/A	0.9

* Coverage includes a gap between boards of 6 mm.

A.2 Compatible fasteners

Below is a summary of fasteners available for fixing the Apex family of profiles.

Fastener type	Size (mm)	Length (mm)	Material	Note
S6 decking clip	6.0	38	SS 430	Compatible with boards that have a 6 mm groove height.
S9 decking clip	9.0	38	SS 430	Compatible with boards that have a 9 mm groove height.
Chain Collated decking clip	6.0	19	SS 316 or SS 304	Compatible with boards that have a groove height of between 6 mm and 12 mm. To be used with hand tool.
Clip screw for timber substructure	M 4.2	40	C 1022	Compatible with all listed clips. Two corrosion resistance options
			SS 316	
Clip screw for metal substructure	M 4.2	31	C 1022	Compatible with all listed clips.
Top fixing deck screw for timber	M 5.0	63	C 1022	For 20 to 25 mm thick boards into timber structures greater than 40 mm thick. Two corrosion resistance options.
			SS 305	
Top fixing deck screw for metal	M 5.0	45	C 1022	For 20 to 25 mm thick boards into metal structures 0.8 to 2.0 mm thick.
Top fixing trim screw for timber	M 5.5	48	10 B 21	For 11 to 16 mm thick boards into timber structures greater than 40 mm thick. Two corrosion resistance options.
			SS 316	
Top fixing trim screw for metal	M 5.5	35	10 B 21	For 11 to 18 mm thick boards into metal structures 0.8 to 2.0 mm thick. Two corrosion resistance options.
			SS 410 H	

Appropriate fasteners must be employed relative to applicable legislation, the intended application, and the conditions present. Particular attention should be paid to the corrosion conditions of the site and the state of the substrate available. Applications should adhere to any applicable standards. All timber profiles should be treated appropriately, and all metal profiles should be coated appropriately. Movement of materials within the system can degrade connections over time, and it is prudent that this is avoided or reduced to an acceptable limit where possible. Coatings can degrade over time and regular, proactive maintenance should be employed.

Appendix B

Installation

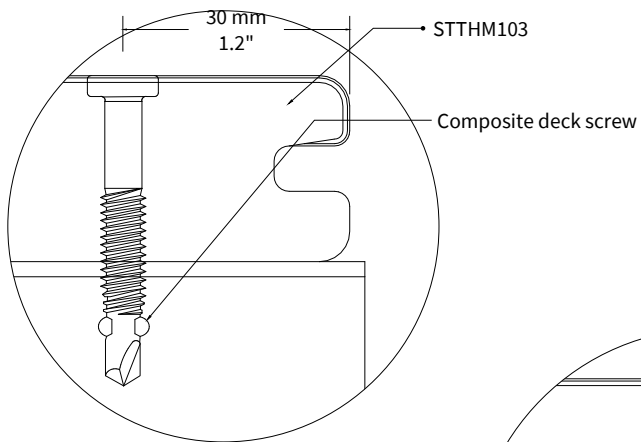
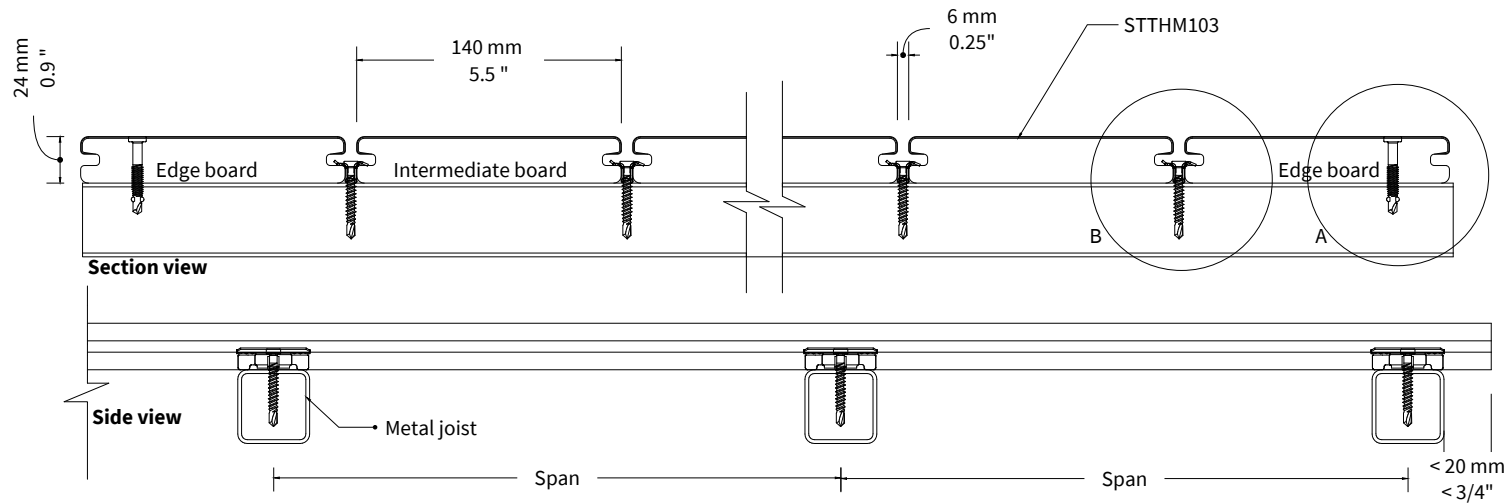

Detail A - Composite deck screw, top fixing application with STTHM103

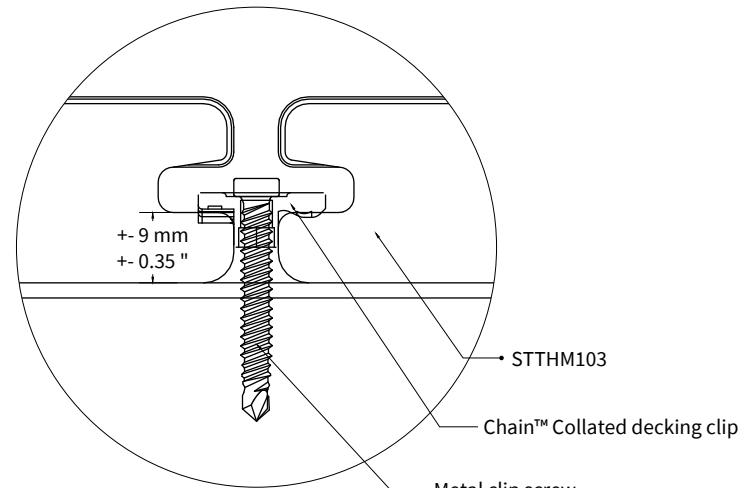

Detail B2 - Chain™ Collated decking clip with STTHM103

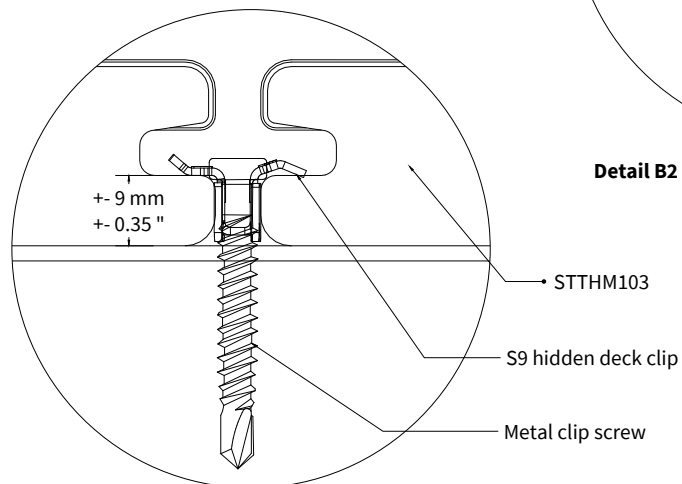

Detail B1 - Hulk S9 Hidden deck fastener with STTHM103

NOTES:
GENERAL
 All dimensions are in millimeters unless otherwise specified.

All queries arising from the above must be reported to the designer immediately.

All dimensions and specifications are offered in good faith as accurate but without guarantee. The information captured herein may not contain complete details. Eva-Last® makes no warranties or representations of any kind (express or implied) about the accuracy, adequacy, currency, or completeness of the information, or that it is necessarily suitable for the intended use.

Compliance with this document does not guarantee immunity from breach of any statutory requirements, building codes or relevant standards. The final responsibility for the correct design and specification rests with the designer and, for its satisfactory execution, with the contractor.

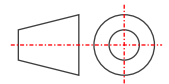

REV:	DATE:	DESCRIPTION:
------	-------	--------------

PROJECT:
 Installation guide board detail

DRAWING TITLE:
 Installation instructions for STTHM103 - metal applications

DWG NO: ADIG20220715A	REV: A
DATE: September 15, 2022	SCALE: 1:1
PAGE A01	

ISSUED FOR INFORMATION

Eva-Last®

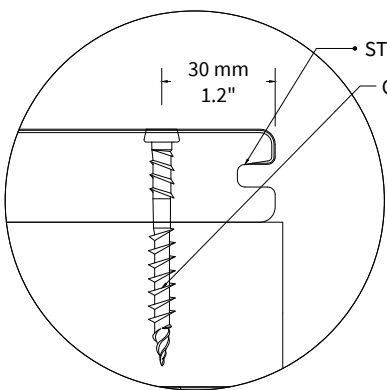
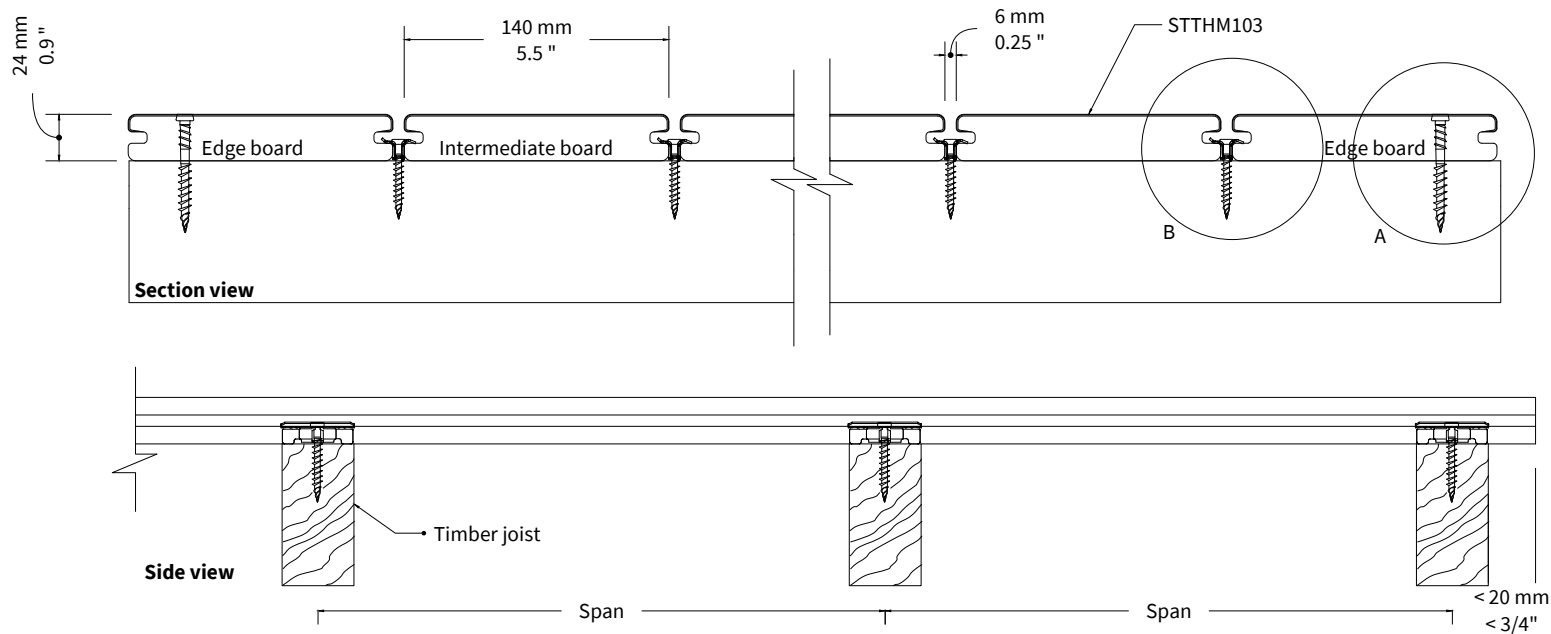

Detail A - Composite deck screw top fixing application with STTHM103

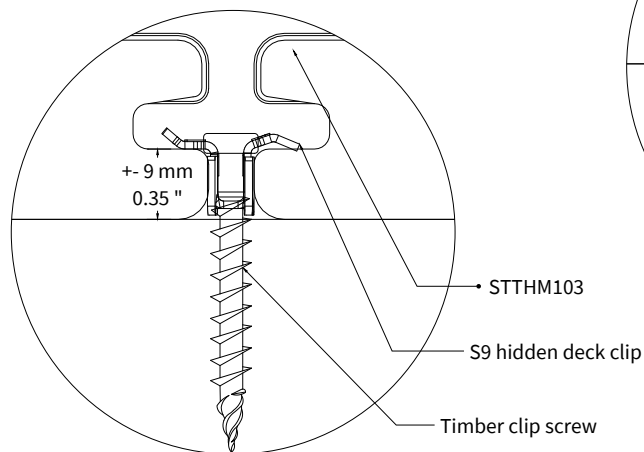

Detail B1 - Hulk S9 Hidden deck fastener with STTHM103

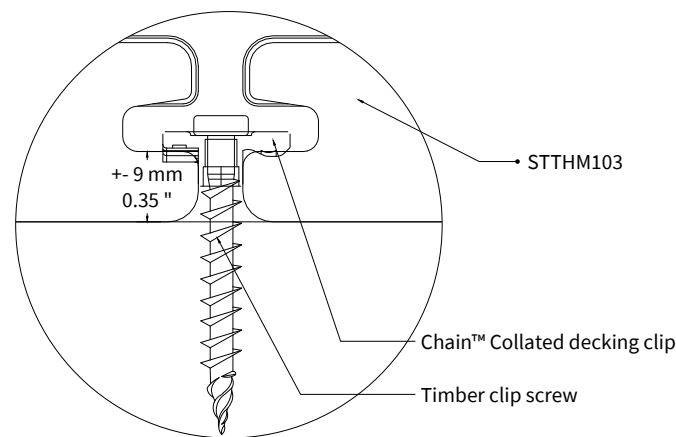

Detail B2 - Chain™ Collated decking clip with STTHM103

NOTES:
GENERAL
All dimensions are in millimeters unless otherwise specified.

All queries arising from the above must be reported to the designer immediately.

All dimensions and specifications are offered in good faith as accurate but without guarantee. The information captured herein may not contain complete details. Eva-Last® makes no warranties or representations of any kind (express or implied) about the accuracy, adequacy, currency, or completeness of the information, or that it is necessarily suitable for the intended use.

Compliance with this document does not guarantee immunity from breach of any statutory requirements, building codes or relevant standards. The final responsibility for the correct design and specification rests with the designer and, for its satisfactory execution, with the contractor.



REV:	DATE:	DESCRIPTION:
------	-------	--------------

PROJECT:
Installation guide board detail

DRAWING TITLE:
Installation instructions for STTHM103 for timber application

DWG NO: ADIG20220715A	REV: A
DATE: September 15, 2022	SCALE: 1:1
	PAGE A02

ISSUED FOR INFORMATION

Eva-Last®

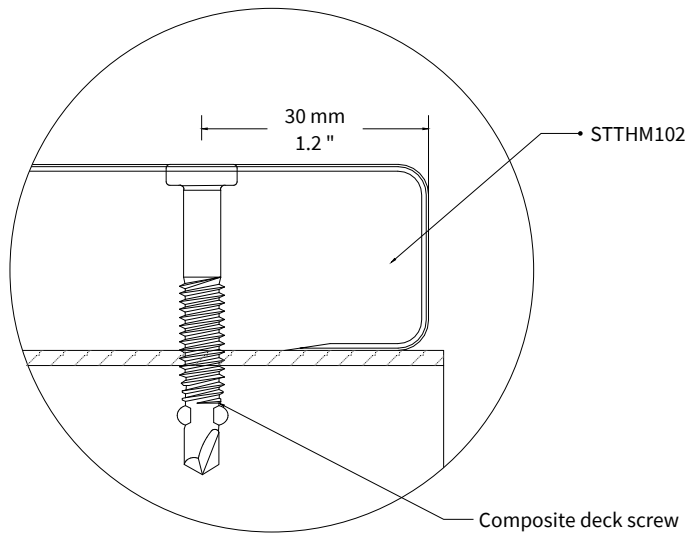
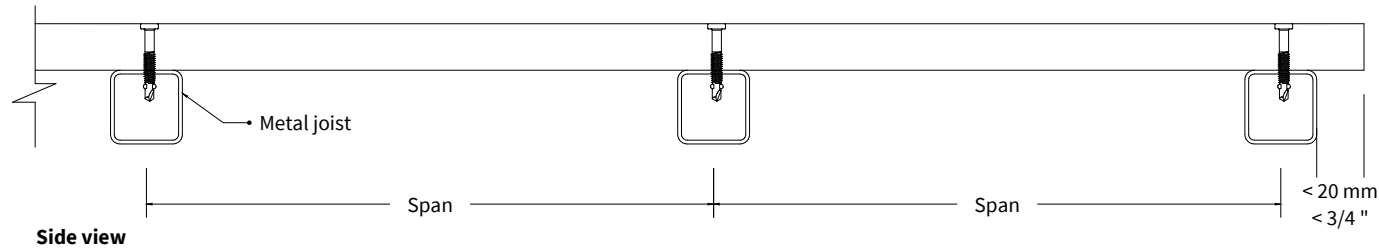
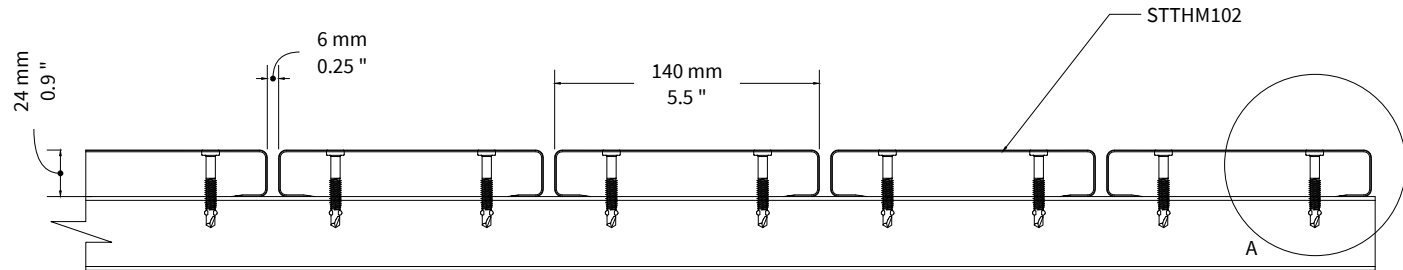

NOTES:
GENERAL
 All dimensions are in millimeters unless otherwise specified.

All queries arising from the above must be reported to the designer immediately.

All dimensions and specifications are offered in good faith as accurate but without guarantee. The information captured herein may not contain complete details. Eva-Last® makes no warranties or representations of any kind (express or implied) about the accuracy, adequacy, currency, or completeness of the information, or that it is necessarily suitable for the intended use.

Compliance with this document does not guarantee immunity from breach of any statutory requirements, building codes or relevant standards. The final responsibility for the correct design and specification rests with the designer and, for its satisfactory execution, with the contractor.

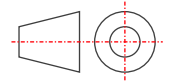

REV:	DATE:	DESCRIPTION:

PROJECT:
 Installation guide board detail

DRAWING TITLE:
 Installation instructions for STTHM102 for metal application

DWG NO: ADIG20220715A	REV: A
DATE: September 15, 2022	SCALE: 1:1
PAGE A03	

ISSUED FOR INFORMATION

Eva-Last®

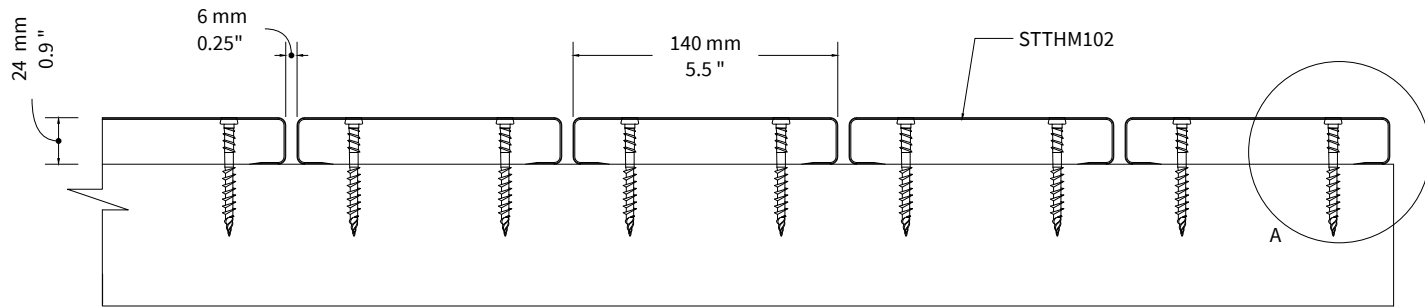

Section view

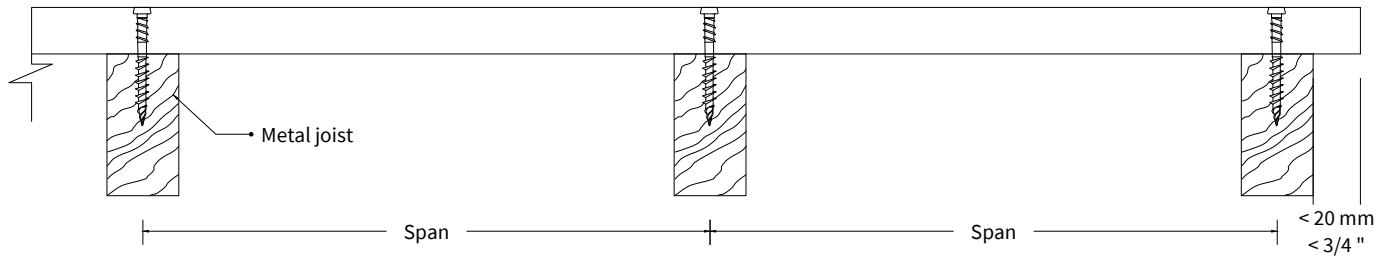

Side view

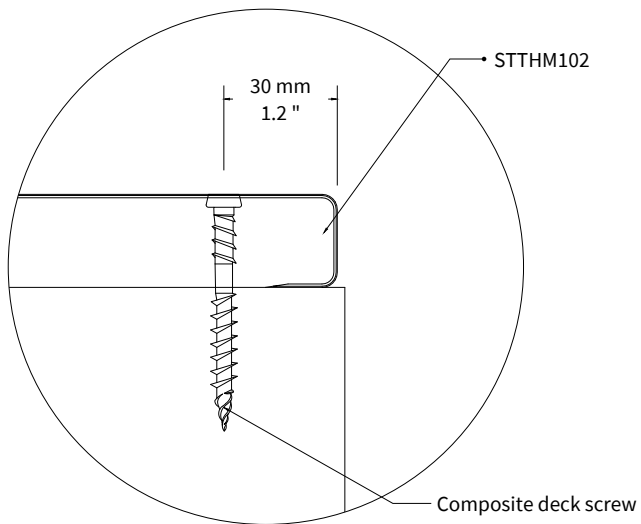

Detail A - Composite deck screw top fixing application with STTHM102

NOTES:
GENERAL
 All dimensions are in millimeters unless otherwise specified.

All queries arising from the above must be reported to the designer immediately.

All dimensions and specifications are offered in good faith as accurate but without guarantee. The information captured herein may not contain complete details. Eva-Last® makes no warranties or representations of any kind (express or implied) about the accuracy, adequacy, currency, or completeness of the information, or that it is necessarily suitable for the intended use.

Compliance with this document does not guarantee immunity from breach of any statutory requirements, building codes or relevant standards. The final responsibility for the correct design and specification rests with the designer and, for its satisfactory execution, with the contractor.

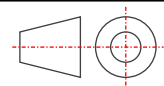

REV:	DATE:	DESCRIPTION:
------	-------	--------------

PROJECT:
 Installation guide board detail

DRAWING TITLE:
 Installation instructions for STTHM102 for timber application

DWG NO:
 ADIG20220715A

REV:
 A

DATE:
 September 15, 2022

SCALE:
 1:1

PAGE
 A04

ISSUED FOR INFORMATION

Eva-Last®

Appendix C

Summary matrix of expansion gaps for different conditions

Summary matrix of estimated expansion gaps (to the nearest 0.5 mm) for Apex material technology at different board lengths and different increases in board temperature relative to the installation temperature.

Board length (m)	Required expansion gap (mm) estimate per increase in temperature relative to the installation temperature (°C)												
	0 (°C)	5 (°C)	10 (°C)	15 (°C)	20 (°C)	25 (°C)	30 (°C)	35 (°C)	40 (°C)	45 (°C)	50 (°C)	55 (°C)	60 (°C)
1.0 m	0	0.5	1.0	1.5	1.5	2.0	2.0	3.0	3.0	3.5	3.5	4.0	4.5
2.0 m	0	1.0	1.5	2.5	3.0	3.5	4.5	6.0	6.0	6.5	7.0	8.0	8.5
3.0 m	0	1.0	2.5	3.5	4.5	5.5	6.5	8.5	8.5	9.5	10.5	12.0	13.0
4.0 m	0	1.5	3.0	4.5	6.0	7.0	8.5	11.5	11.5	13.0	14.0	15.5	17.0
5.0 m	0	2.0	3.5	5.5	7.0	9.0	10.5	14.0	14.0	16.0	17.5	19.5	21.0
5.45 m	0	2.0	4.0	6.0	8.0	10.0	11.5	15.0	15.0	17.5	19.0	21.0	23.0
5.8 m	0	2.5	4.5	6.5	8.5	10.5	12.5	16.5	16.5	18.5	20.5	22.5	24.5

Appendix D

Corrosion references

Fastener Life expectancy

Screw corrosion classification

The following table provides a summary of typical fasteners, their coating thicknesses, and respective lifespans in different corrosion zones. In all cases consult an appropriately qualified professional.

Red - the fastener is not suitable

Orange - The protective coating is suitable for some composite product systems. See appropriate TDS document for more information.

Green - The coating is suitable for the given environment and most composite systems

Tick(✓) - The material itself is suitable for the given environment and most composite systems

Fastener category	ISO 9223 corrosion category		C3	C4	C5	C5+	
	Material	Coating	Zinc corrosion rate	0.7 to 2.1 (µm/annum)	2.1 to 4.2 (µm/annum)	4.2 to 8.4 (µm/annum)	8.4 to 25 (µm/annum)
			Coating Thickness	Expected lifespan of fastener coatings (years)			
Carbon clip screws							
Carbon deck screws	C1022	Magni 599 (full coat)	20 µm	10 to 28	5 to 10	2 to 5	< 1 to 2
Carbon Frame screws							
Carbon trim screws	10B21		20 µm	10 to 28	5 to 10	2 to 5	< 1 to 2
Tek screw	C1022	Class 3	25 µm	12 to 35	6 to 12	3 to 6	1 to 3
		Class 4	50 µm	24 to 72	12 to 24	6 to 12	2 to 6
		Zinc plated	8 µm				
Stainless Steel S clips	SS430	Enamel		✓	✓		
Stainless clip screw		Magni 599 (full coat)	20 µm	10 to 28 + ✓	5 to 10 + ✓	2 to 5 + ✓	< 1 to 2 + ✓
Stainless deck screw	SS316	Enamel head coating	N/a	✓	✓	✓	
Stainless trim screw							
Stainless chain clip	SS316	Polypropylene (PP)	600 µm	✓	✓	63 to 130 ✓	✓

Material corrosion rates

The following table provides typical corrosion rates ($\mu\text{m} / \text{annum}$) for common materials seen in composite building systems. Not all materials are published in relation to ISO 9223 corrosion rates but are indicated by source material as suitable for certain environments. It has been assumed that references to a marine environment would be equivalent to a C5 environment.

Corrosion rates ($\mu\text{m}/\text{annum}$) of constituents in different corrosion zones						
Material Category	ISO 9223 corrosion category	C3	C4	C5	C5+	Note
	Equivalent category	Rural	Urban	Marine	Marine Industrial	
Zinc		0.7 to 2.1	2.1 to 4.2	4.2 to 8.4	8.4 to 25	
Copper		0.6 to 1.3	1.3 to 2.8	2.8 to 5.6	5.6 to 10	Per published ISO 9223 rates
Aluminium		Negligible				
Steel	Carbon	25 to 50	50 to 80	80 to 200	200 to 700	
Stainless steel	SS410	✓	x	x	x	Per ASKzn website. Unrelated to ISO 9223
	SS430	✓	✓	0.0381	0.0406	
	SS316	✓	✓	0.0051	0.0076	
Plastics	Polypropylene (PP)	✓	✓		4.6 to 7.5	Per online sources. Unrelated to ISO 9223
	Polypropylene (PE)	✓	✓		4.3 to 9.5	

Appendix E

Troubleshooting

Common complaints	Typical issues	Potential solution
Deck is bouncy or springy.	Inappropriate spans.	Reduce spans and/or provide additional supports.
Deck boards sag between joists.	Inappropriate spans.	Reduce spans and/or provide additional supports.
Deck board ends lift or tent.	Inappropriate fastening distance from edge of the board and/or overhang.	Fasten board down closer to the board edge. Ensure board support and substructure are adequate. Ensure appropriate overhang distance.
Expansion gap is too large.	The installed gap did not consider potential minimum board temperatures for the site.	Refit using appropriate expansion gaps. Make use of shorter boards and/or breaker boards.
Ends of the deck boards are no longer even.	Boards were not left to acclimatise before installation and/or boards were installed at different temperatures without allowing for this.	Now that the boards have acclimatised, cut the boards to the same lengths. Ensure this is done at a consistent temperature to avoid similar problems in the future.
Boards 'tent' at butt joints.	Inappropriate expansion gaps.	Calculate correct expansion gap for site and cut board ends to satisfy. Make use of breaker boards and similar where possible.
Board end sags under load.	Inappropriate board overhang.	Ensure board end is adequately supported within 20 mm of board end.
Screws snapping.	Inappropriate number of fasteners per board and/or over-tightening/over-torquing of screws and/or incorrect fastener utilised for the application.	Ensure appropriate fastener is used. Ensure two fasteners (hidden clips or top fixings) are used at every joist. Ensure appropriate torque settings are utilised.
Boards are cracking at board edges in vicinity of top-fixing screws.	Inappropriate fastening edge distance and/or pre-drilling.	Replace board and ensure top fixing to edge distances are correct. Pre-drill in low-temperature installations.
'Mushrooming' occurring at top-fixings.	Over-tightening/over-torquing of screws and/or high deck board temperatures during installation.	Ensure appropriate torque settings are utilised. Avoid installations at particularly high site temperatures. Pre-drill the fastening holes.
Deck is squeaky.	Board-clip-substructure interaction is producing a noise when loaded.	Replace hidden fastener with a smaller fastener and/or a fastener with a suitable polymer coating.
Strands of glass fiber of visible after cutting	Blades used to cut the board are not sharp or fast enough	Trim the strands with a sharp blade and dispose of the strands in accordance with health and safety requirements.